

Dimensions in "mm"

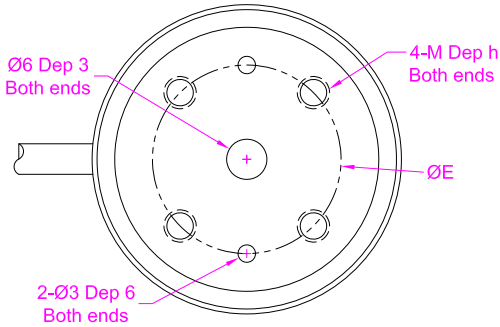
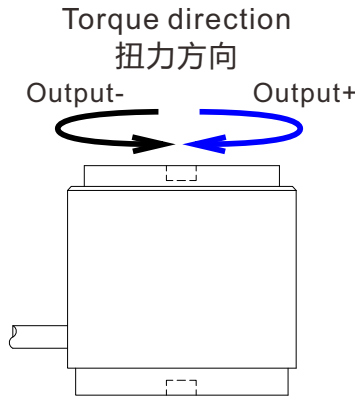
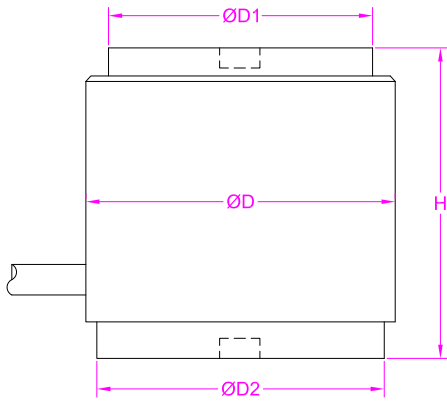

**Ordering code**  
**FTE - 1NM**  
 Model Capacity

P-1/2

Wiring Diagram/接线图

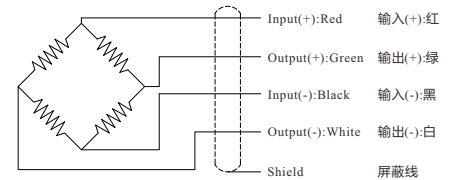

Capacity(NM)	H	D	D1	D2	E	M	h
0.1~20	31.8	41	35	38.1	25	M5	6
30/50/100	44.8	46	40	43.1	27	M6	9

--- Specifications / 规格参数 ---

Capacity/量程	0.1/0.2/0.5/1/2/3/5/10/20/30/50/100NM		
Rated Output 额定输出	1.0mV/V	Compensated Temp. 温度补偿范围	-10...+40°C
Excitation 激励电压	3~15V	Operating Temp. 工作温度范围	-20...+60°C
Zero Balance 零点输出	±0.05mV/V	Temp. Shift Zero 零点温度漂移	±0.02% of R.O./°C
Nonlinearity 非线性	±0.2% of R.O.	Temp. Shift Span 灵敏度温度漂移	±0.02% of R.O./°C
Hysteresis 滞后	±0.2% of R.O.	Input Resistance 输入阻抗	700±50Ω
Nonrepeatability 非重复性	±0.1% of R.O.	Output Resistance 输出阻抗	700±10Ω
Creep(10min) 蠕变(10min)	±0.1% of R.O.	Insulation Resistance 绝缘阻抗	>2000MΩ(50V)
Safe Overload 安全过载	150% of F.S.	Ingress Protection 防护等级	IP50
Ultimate Overload 极限过载	200% of F.S.	Material of Element 弹性体材料	≤5NM Aluminum alloy ≥10NM Stainless steel
Cable 导线	Ø3*3000mm 4-core shielded cable Ø3*3000mm 4芯屏蔽线		
R.O.=Rated Output/额定输出 F.S.=Full Scale/满量程			

• Subject to change without notice / 如有更改,不另行通知

## Custom torque sensor

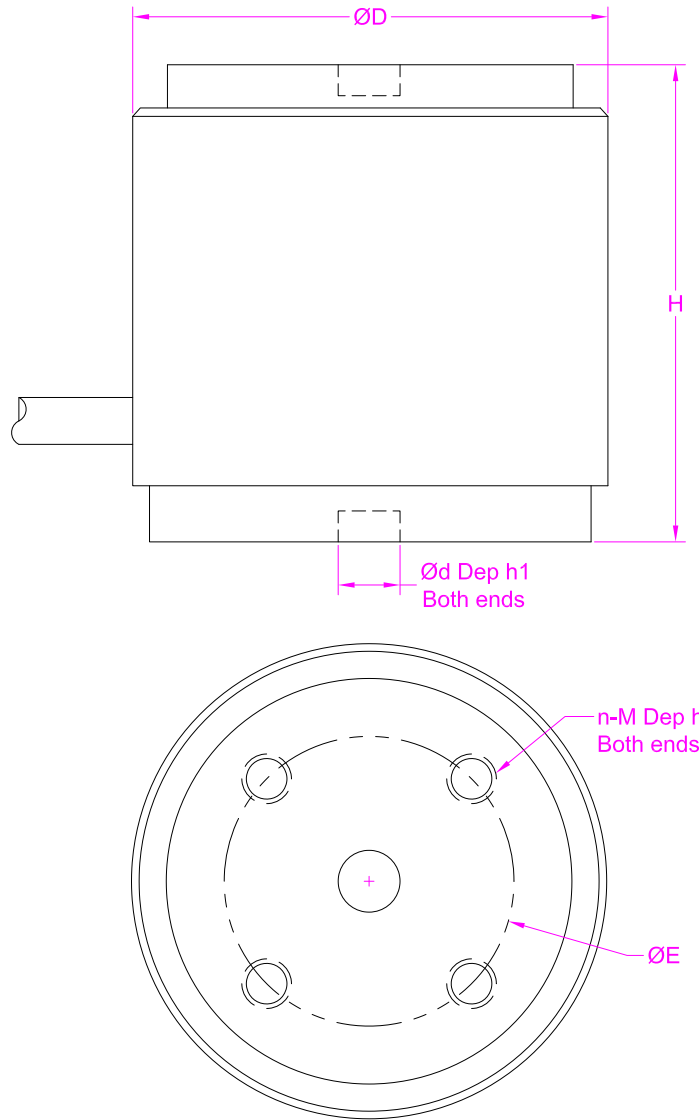

P-2/2

Capacity(NM)		Quantity	
H		D	
d		h1	
n		M	
h		E	
Other requirements			

- For dimensions that don't matter, please fill in "Given by design" or acceptable range like "25~40mm".
- Drawings provided by clients are also welcome.
- Forsentek will evaluate the feasibility upon the given parameters and propose modifications accordingly to make it work.