

Dimensions in "mm"

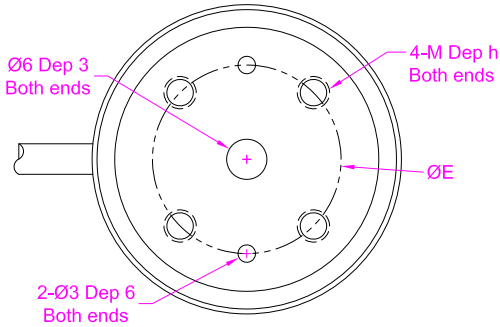
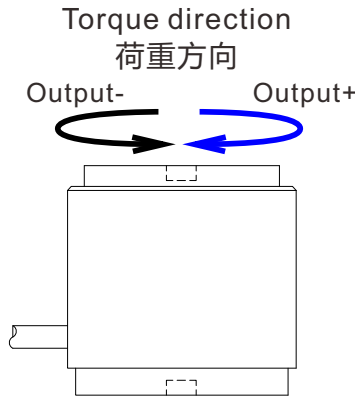
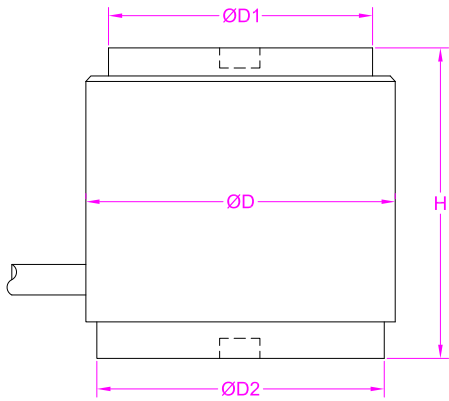

Capacity(NM)	H	D	D1	D2	E	M	h
0.1~20	31.8	41	35	38.1	25	M5	6
30/50/100	44.8	46	40	43.1	27	M6	9

Ordering code
FTE - 1NM
 Model Capacity

P-1/2

Wiring Diagram/配線図

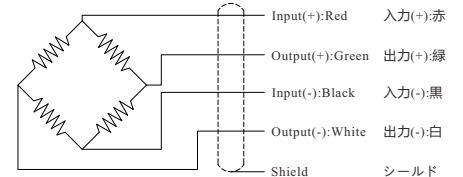

--- Specifications / 仕様 ---

Capacity/定格容量	0.1/0.2/0.5/1/2/3/5/10/20/30/50/100NM		
Rated Output 定格出力	1.0mV/V	Compensated Temp. 温度補償範囲	-10...+40°C
Excitation 供給電圧	3~15V	Operating Temp. 動作温度範囲	-20...+60°C
Zero Balance 零バランス	±0.05mV/V	Temp. Shift Zero 零点の温度影響	±0.02% of R.O./°C
Nonlinearity 非直線性	±0.2% of R.O. 0.1Nm: ±0.3% of R.O.	Temp. Shift Span 出力の温度影響	±0.02% of R.O./°C
Hysteresis ヒステリシス	±0.2% of R.O. 0.1Nm: ±0.3% of R.O.	Input Resistance 入力抵抗	700±50Ω
Nonrepeatability 繰り返し性	±0.1% of R.O.	Output Resistance 出力抵抗	700±10Ω
Creep(10min) クリープ(10min)	±0.1% of R.O.	Insulation Resistance 絶縁抵抗	>2000MΩ(50V)
Safe Overload 許容過負荷	150% of F.S.	Ingress Protection 防塵防水	IP50
Ultimate Overload 限界過負荷	200% of F.S.	Material of Element 起歪体の材質	≤5NM Aluminum alloy ≥10NM Stainless steel
Cable ケーブル	Ø3*3000mm 4-core shielded cable Ø3*3000mm 4芯シールドケーブル		
R.O.=Rated Output/定格出力 F.S.=Full Scale/フルスケール			

• Subject to change without notice / 予告なしに変更されることが

Custom torque sensor

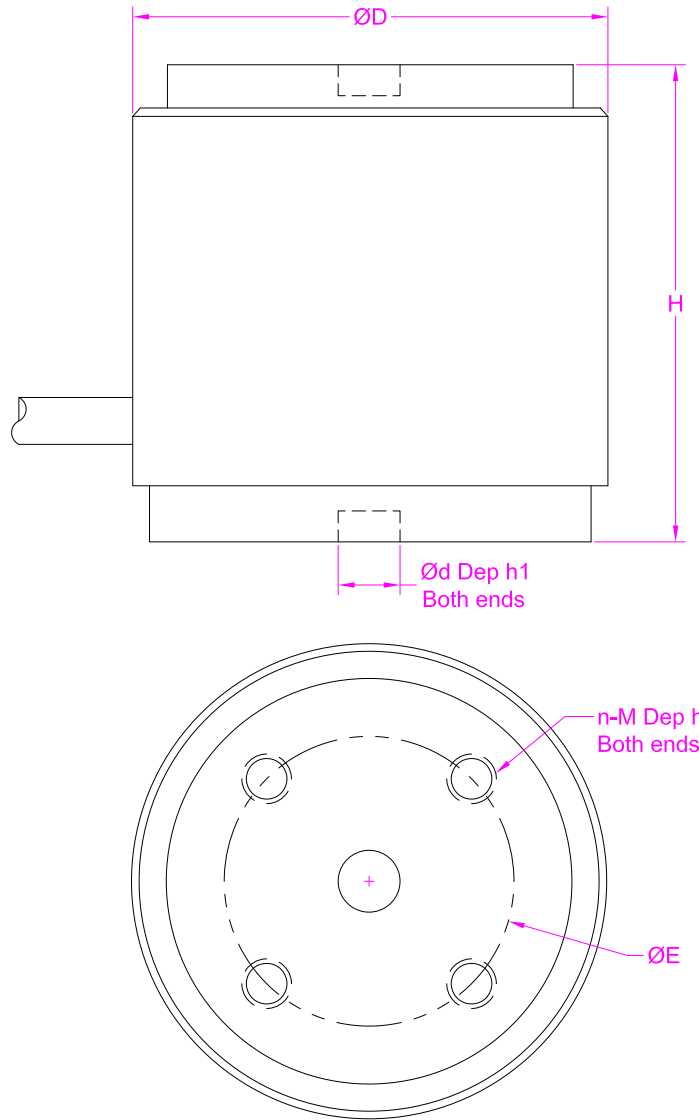

P-2/2

Capacity(NM)		Quantity	
H		D	
d		h1	
n		M	
h		E	
Other requirements			

- For dimensions that don't matter, please fill in "Given by design" or acceptable range like "25~40mm".
- Drawings provided by clients are also welcome.
- Forsentek will evaluate the feasibility upon the given parameters and propose modifications accordingly to make it work.