

Capacity (NM)	D
10-700	9
1000	11

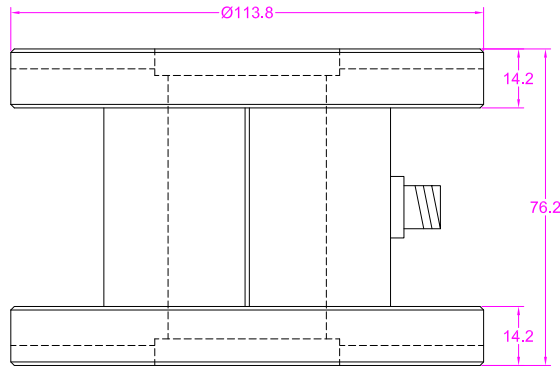

Ordering code
FTF - 100NM
 Model Capacity

Wiring Diagram/接线图

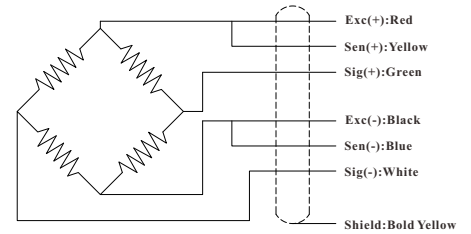

P-1/2

--- Specifications / 仕様 ---

Capacity/定格容量	10/20/30/50/100/200/300/500/700/1000NM		
Rated Output 定格出力	1.0 mV/V	Compensated Temp. 温度補償範囲	-10...+40°C
Excitation 供給電圧	3~15V	Operating Temp. 動作温度範囲	-20...+60°C
Zero Balance 零バランス	±0.05mV/V	Temp. Shift Zero 零点の温度影響	±0.02% of R.O./°C
Nonlinearity 非直線性	±0.2% of R.O.	Temp. Shift Span 出力の温度影響	±0.02% of R.O./°C
Hysteresis ヒステリシス	±0.2% of R.O.	Input Resistance 入力抵抗	750±100Ω
Nonrepeatability 繰り返し性	±0.2% of R.O.	Output Resistance 出力抵抗	700±10Ω
Creep(10min) クリープ(10min)	±0.1% of R.O.	Insulation Resistance 絶縁抵抗	>2000MΩ(50V)
Safe Overload 許容過負荷	150% of F.S.	Ingress Protection 防塵防水	IP50
Ultimate Overload 限界過負荷	200% of F.S.	Material of Element 起歪体の材質	≤300NM Aluminum alloy ≥500NM Stainless steel
Cable ケーブル	Ø5.8*4000mm 6-core shielded cable with mating connector Ø5.8*4000mm 6芯シールドケーブル		
R.O.=Rated Output/定格出力 F.S.=Full Scale/フルスケール			

• Subject to change without notice / 予告なしに変更されることが

Custom torque sensor

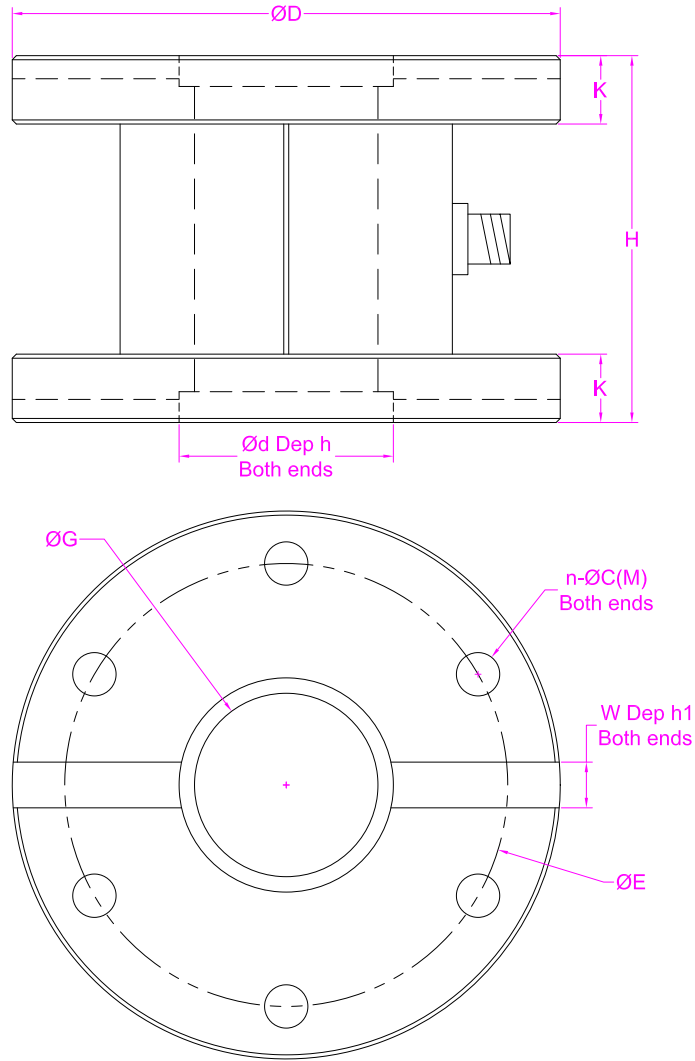

P-2/2

Capacity(NM)		Quantity	
H		K	
D		E	
n		C(M)	
d		h	
W		h1	
G		/	/
Other requirements			

- For dimensions that don't matter, please fill in "Given by design" or acceptable range like "25~40mm".
- Drawings provided by clients are also welcome.
- Forsentek will evaluate the feasibility upon the given parameters and propose modifications accordingly to make it work.